

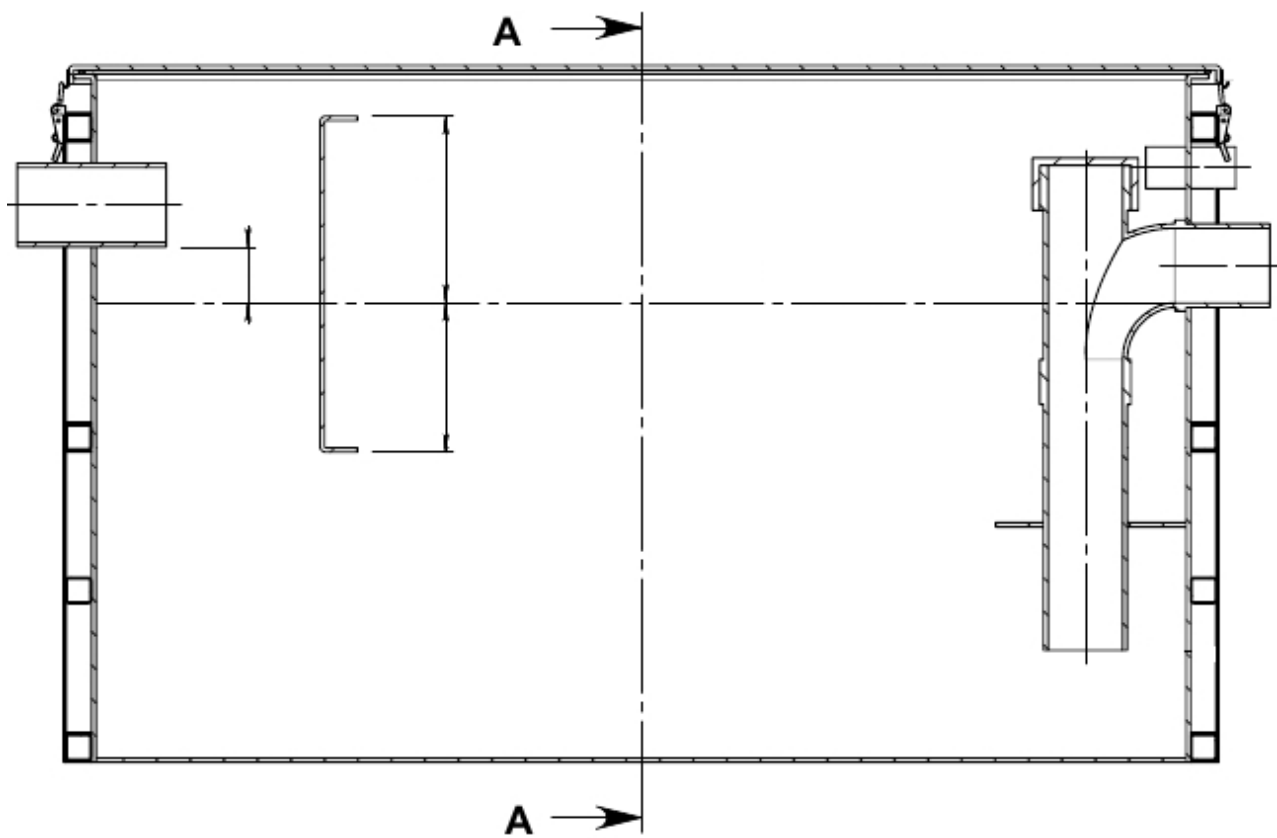

TRADE WASTE CATALOGUE



T: (03) 9775 0203

When it comes to quality built Trade Waste Equipment and excellent service look no further than Pioneer. With more than 40 Years Plumbing Industry and manufacturing experience, Pioneer is the only choice you should make for all Trade Waste Equipment enquiries. Made to Trade Waste design specifications or client's design our range of equipment sizes is almost unlimited.

THE PIONEER POINT OF DIFFERENCE

- Various materials available for specific fabrication requirements
 - On-site repairs including plastic welding
- Sales of sheet acrylic, Polyvinyl Chloride (P.V.C) and other associated equipment.
 - General information including telephone quoting, design advice, etc
 - Prompt processing and manufacture of orders

OTHER PIONEER PRODUCTS & SERVICES

- LIGHT & HEAVY DUTY CAST IRON COVERS TO SUIT BELOW GROUND RANGE OF TANKS
 - FUME CUPBOARDS
 - FUME EXTRACTION SYSTEMS
- ALL FABRICATION IN POLYPROPYLENE, PVC & PERSPEX
- ONSITE REPAIRS IN ALL OF THE ABOVE MATERIALS
 - DOSING TANKS
 - TROUGHS & TRAYS
 - CUSTOM FABRICATED SINKS
 - PLATING TANKS
 - HOODS
 - STORAGE CUPBOARDS
- PVC DUCTING-ROUND & RECTANGULAR
 - COWLS
- MACHINERY COVERS AND GUARDS
 - BENCH TOPS
- LABORATORY TAP-WARE & FITTINGS
 - RAIN HEADS
 - CHANNELS
- ADVERTISING MODELS
- PERSPEX, POLYCARB AND PVC SHEET SALES

ABOVE GROUND FOOD & OIL INTERCEPTOR ABOVE GROUND GREASE TRAP/INTERCEPTOR

PP AG1

SECTION VIEW

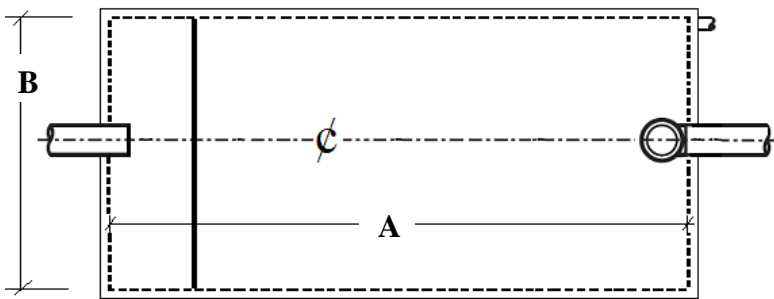
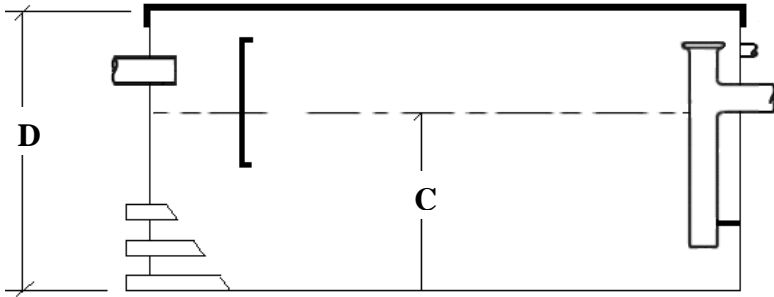

PLAN VIEW

CAPACITY LITERS	A (L)	B (W)	C (WL)	D (D)
100	600	380	450	595
150	750	450	450	595
200	825	550	450	595
250	930	600	450	750
300	1180	600	450	750
400	1180	600	600	900
600	1460	830	510	810
800	1460	830	680	980
1000	1460	830	850	1150
1100	1460	830	930	1230
1500	1460	830	1270	1570
2000	2000	950	1060	1360
2500	2960	950	890	1190
3000	2960	950	1080	1380
3500	2960	1460	830	1130
4000	2960	1460	950	1250
4500	2960	1460	1070	1370
5000	2960	1460	1190	1490

NOTE-DIMENSIONS IN MILLIMETERS

- ✓ Designed for above ground installations
- ✓ Manufactured from 6mm Polypropylene or PVC.
- ✓ Factory fitted with inlet/outlet/vent connections standard
- ✓ Removable air tight covers supplied with all tanks
- ✓ Tanks larger than 399 liters capacity have external bracing fitted for strength & support. Add an additional 100mm to the length and width dimensions for the approximate size when steel rails are fitted
- ✓ When space limitations apply, equivalent capacity tanks can be manufactured to order. Inlet, outlet and vent positions can be altered to suit clients specific needs

OTHER PIONEER PRODUCTS INCLUDE-

- BELOW GROUND FOOD & OIL INTERCEPTOR/GREASE TRAP
- MIXING TANKS
- ACID NEUTRALIZING TANK
- SOLVENT & OIL INTERCEPTOR
- PETROL & OIL INTERCEPTOR
- SETTLING TANK/PLASTER TRAP
- COOLING & STRAINING TANK
- PUMP STATIONS
- PAINT SETTLING TANK
- TESTING SUMP
- SILT TRAP
- SILT PIT
- LIGHT & HEAVY DUTY GATIC ACCESS COVERS
- PHOTOGRAPHIC SINK
- SMALL & LARGE VALVE BOXES
- CUSTOM FABRICATION OF PVC, POLYPROPYLENE & PERSPEX

Pioneer Plastics
3/2137 Frankston-Flinders Rd,
Hastings 3915

p-(03) 9775 0203
sales@pioneerplastics.com.au

BELOW GROUND FOOD & OIL INTERCEPTOR BELOW GROUND GREASE TRAP/INTERCEPTOR

SECTION VIEW

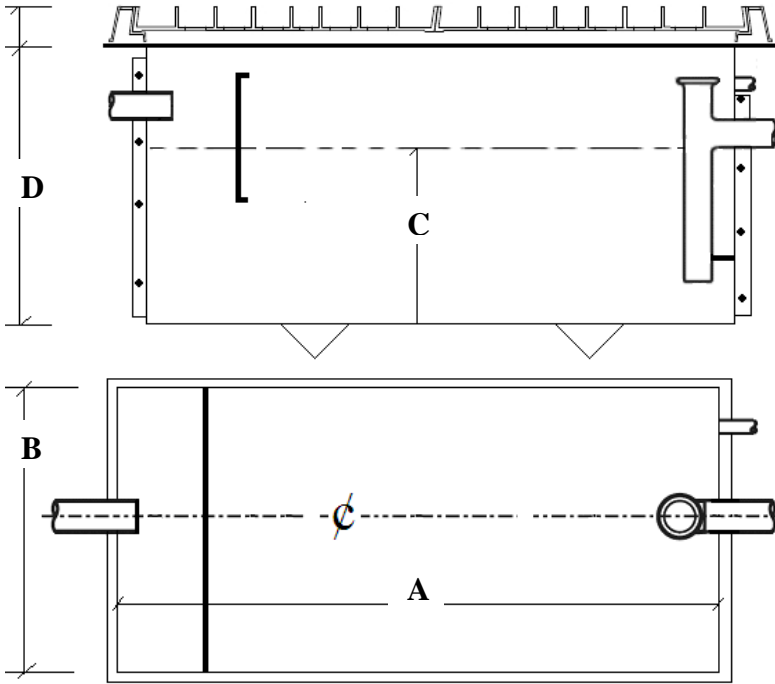

PLAN VIEW

PP BG1

CAPACITY LITRES	A (L)	B (W)	C (WL)	D (D)
250	900	600	470	770
300	900	600	560	860
400	900	600	750	1050
600	1500	600	670	970
800	1500	600	900	1200
1100	1500	600	1230	1530
1500	2000	750	1000	1300
2000	2500	750	1070	1370
2500	1900	1200	1100	1400
3000	2800	1200	900	1200
3500	2800	1200	1050	1350
4000	2800	1200	1200	1500
4500	2800	1200	1340	1640
5000	2800	1200	1490	1790

NOTE-DIMENSIONS IN MILLIMETERS

- ✓ Designed for below ground installations
- ✓ Manufactured from 6mm Polypropylene or PVC
- ✓ Factory fitted with 100mm inlet/outlet/vent connections standard
- ✓ Cast iron access covers capable of being removed by one person should be fitted (**available at additional cost**)
- ✓ Tanks must be surrounded with 100mm thick concrete walls & base
- ✓ When space limitations apply, equivalent capacity tanks can be manufactured to order. Inlet, outlet and vent positions can be altered to suit clients specific needs

OTHER PIONEER PRODUCTS INCLUDE-

- ABOVE GROUND FOOD & OIL INTERCEPTOR/GREASE TRAP
- MIXING TANKS
- ACID NEUTRALIZING TANK
- SOLVENT & OIL INTERCEPTOR
- PETROL & OIL INTERCEPTOR
- SETTLING TANK/PLASTER TRAP
- COOLING & STRAINING TANK
- PUMP STATIONS
- PAINT SETTLING TANK
- TESTING SUMP
- SILT TRAP
- SILT PIT
- LIGHT & HEAVY DUTY GATIC ACCESS COVERS
- PHOTOGRAPHIC SINK
- SMALL & LARGE VALVE BOXES
- CUSTOM FABRICATION OF PVC, POLYPROPYLENE & PERSPEX

Pioneer Plastics
3/2137 Frankston-Flinders Rd,
Hastings 3915

p-(03) 9775 0203
sales@pioneerplastics.com.au

ABOVE GROUND MIXING TANK

PP AG2

SECTION VIEW

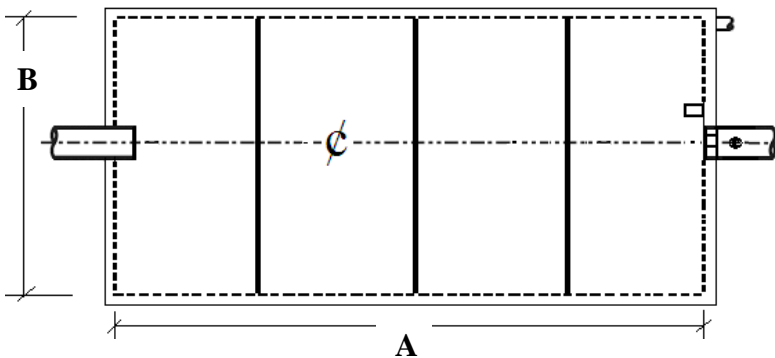
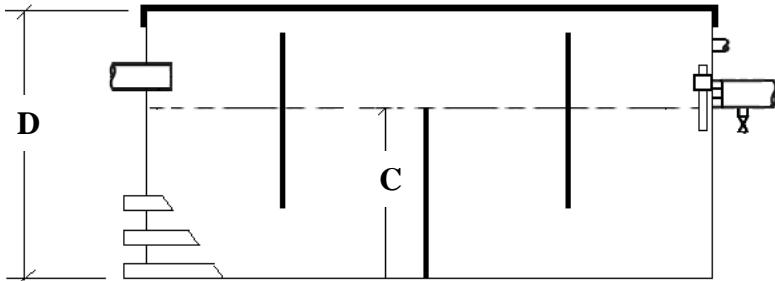

PLAN VIEW

CAPACITY LITRES	A (L)	B (W)	C (WL)	D (D)
100	610	410	400	550
150	750	450	450	600
200	750	450	600	750
250	1180	500	450	750
300	1180	600	450	750
400	1180	600	600	900
600	1460	830	510	810
800	1460	830	680	980
1000	1460	830	850	1150
1100	1460	830	930	1230
1500	1460	830	1270	1570
2000	2000	950	1060	1360
2500	2960	950	890	1190
3000	2960	950	1080	1380
3500	2960	1460	830	1130
4000	2960	1460	950	1250
4500	2960	1460	1070	1370
5000	2960	1460	1190	1490

NOTE-DIMENSIONS IN MILLIMETERS

- ✓ Designed for above ground installations
- ✓ Manufactured from 6mm Polypropylene or PVC
- ✓ Factory fitted with inlet/outlet/vent connections standard
- ✓ Cement mortar test block to be supplied & fitted by Trade Waste Inspector
- ✓ Standard fittings supplied with tank-
 - 3 equally spaced baffles
 - bracket only for Test Block
 - sampling valve socket & drum tap
 - Removable air tight covers supplied with all tanks **(Loose fitting lids not acceptable due to odors created by waste water)**
- ✓ Tanks larger than 399 liters capacity have external bracing fitted for strength & support. Add an additional 100mm to the length and width dimensions for the approximate size when steel rails are fitted
- ✓ When space limitations apply, equivalent capacity tanks can be manufactured to order. Inlet, outlet and vent positions can be altered to suit clients specific needs

OTHER PIONEER PRODUCTS INCLUDE-

- ABOVE & BELOW GROUND FOOD & OIL INTERCEPTOR/GREASE TRAP
- BELOW GROUND MIXING TANKS
- ACID NEUTRALIZING TANK
- SOLVENT & OIL INTERCEPTOR
- PETROL & OIL INTERCEPTOR
- SETTLING TANK/PLASTER TRAP
- COOLING & STRAINING TANK
- PUMP STATIONS
- PAINT SETTLING TANK
- TESTING SUMP
- SILT TRAP
- SILT PIT
- LIGHT & HEAVY DUTY GATIC ACCESS COVERS
- PHOTOGRAPHIC SINK
- SMALL & LARGE VALVE BOXES
- CUSTOM FABRICATION OF PVC, POLYPROPYLENE & PERSPEX

Pioneer Plastics
 3/2137 Frankston-Flinders Rd,
 Hastings, 3915

p-(03) 9775 0203
 sales@pioneerplastics.com.au

BELOW GROUND MIXING TANK

PP BG2

SECTION VIEW

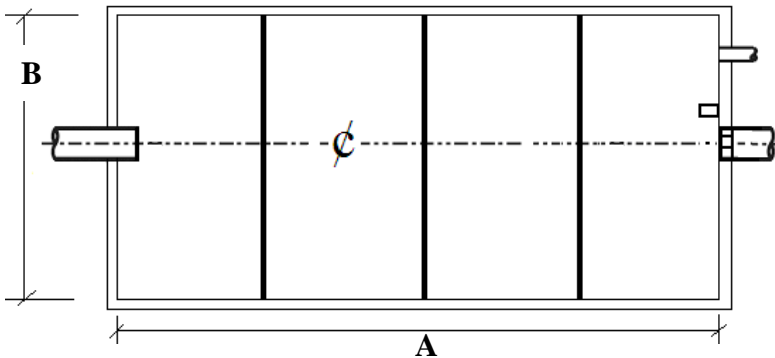
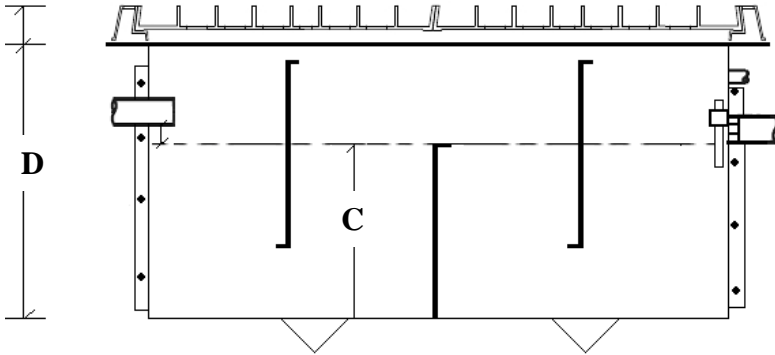

PLAN VIEW

CAPACITY LITRES	A (L)	B (W)	C (WL)	D (D)
250	900	600	470	770
300	900	600	560	860
400	900	600	750	1050
600	1500	600	670	970
800	1500	600	900	1200
1100	1500	600	1230	1530
1500	2000	750	1000	1300
2000	2500	750	1070	1370
2500	1900	1200	1100	1400
3000	2800	1200	900	1200
3500	2800	1200	1050	1350
4000	2800	1200	1200	1500
4500	2800	1200	1340	1640
5000	2800	1200	1490	1790

NOTE-DIMENSIONS IN MILLIMETERS

- ✓ Designed for below ground installations
- ✓ Manufactured from 6mm Polypropylene or PVC
- ✓ Factory fitted with 100mm inlet/outlet/vent connections standard
- ✓ Cement mortar test block to be supplied & fitted by Trade Waste Inspector
- ✓ Standard fittings supplied with tank-
- 3 equally spaced baffles
- bracket only for Test Block
- inlet/outlet/vent connections are 100mm
- Cast iron access covers capable of being removed by one person should be fitted (**available at additional cost**)
- ✓ Tanks must be surrounded with 100mm thick concrete walls & base
- ✓ When space limitations apply, equivalent capacity tanks can be manufactured to order. Inlet, outlet and vent positions can be altered to suit clients specific needs

OTHER PIONEER PRODUCTS INCLUDE-

- ABOVE & BELOW GROUND FOOD & OIL INTERCEPTOR/GREASE TRAP
- ABOVE GROUND MIXING TANKS
- ACID NEUTRALIZING TANK
- SOLVENT & OIL INTERCEPTOR
- PETROL & OIL INTERCEPTOR
- SETTLING TANK/PLASTER TRAP
- COOLING & STRAINING TANK
- PUMP STATIONS
- PAINT SETTLING TANK
- TESTING SUMP
- SILT TRAP
- SILT PIT
- LIGHT & HEAVY DUTY GATIC ACCESS COVERS
- PHOTOGRAPHIC SINK
- SMALL & LARGE VALVE BOXES
- CUSTOM FABRICATION OF PVC, POLYPROPYLENE & PERSPEX

Pioneer Plastics
3/2137 Frankston-Flinders Rd,
Hastings 3915

p-(03) 9775 0203
sales@pioneerplastics.com.au

ABOVE GROUND ACID NEUTRALIZING TANK

PP AG3

SECTION VIEW

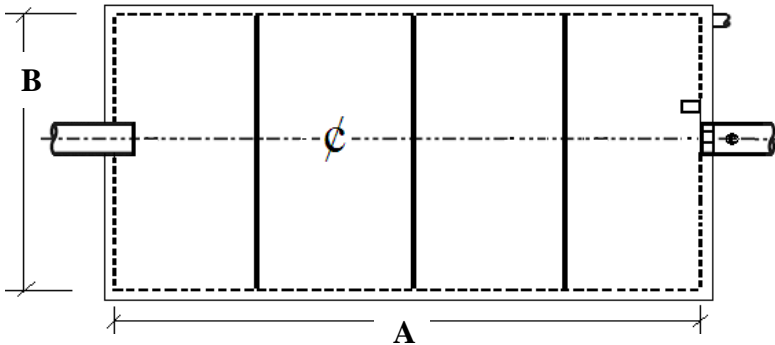
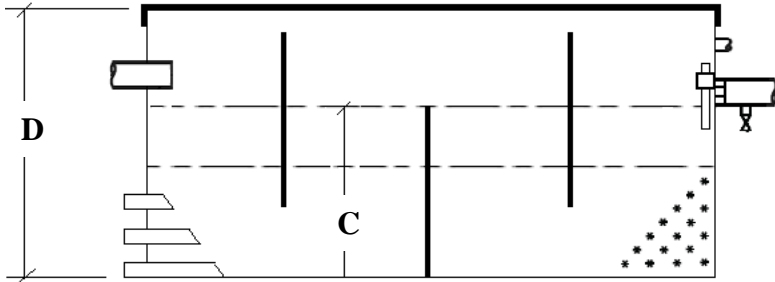

PLAN VIEW

CAPACITY LITRES	A (L)	B (W)	C (WL)	D (D)
100	610	410	400	550
150	750	450	450	600
200	750	450	600	750
250	1180	500	450	750
300	1180	600	450	750
400	1180	600	600	900
600	1460	830	510	810
800	1460	830	680	980
1000	1460	830	850	1150
1100	1460	830	930	1230
1500	1460	830	1270	1570
2000	2000	950	1060	1360
2500	2960	950	890	1190
3000	2960	950	1080	1380
3500	2960	1460	830	1130
4000	2960	1460	950	1250
4500	2960	1460	1070	1370
5000	2960	1460	1190	1490

NOTE-DIMENSIONS IN MILLIMETERS

- ✓ Designed for above ground installations
- ✓ Manufactured from 6mm Polypropylene or PVC
- ✓ Factory fitted with inlet/outlet/vent connections standard
- ✓ Cement mortar test block to be supplied & fitted by Trade Waste Inspector
- ✓ Standard fittings supplied with tank-
 - 3 equally spaced baffles
 - bracket only for Test Block
 - sampling valve socket
- Removable air tight covers supplied with all tanks
(Loose fitting lids not acceptable due to odors created by waste water)
- ✓ **Marble chips available at additional cost.**
- ✓ Tanks larger than 399 liters capacity have external bracing fitted for strength & support. Add an additional 100mm to the length and width dimensions for the approximate size when steel rails are fitted
- ✓ When space limitations apply, equivalent capacity tanks can be manufactured to order. Inlet, outlet and vent positions can be altered to suit clients specific needs

OTHER PIONEER PRODUCTS INCLUDE-

- ABOVE & BELOW GROUND FOOD & OIL INTERCEPTOR/GREASE TRAP
- MIXING TANKS
- BELOW GROUND ACID NEUTRALIZING TANK
- SOLVENT & OIL INTERCEPTOR
- PETROL & OIL INTERCEPTOR
- SETTLING TANK/PLASTER TRAP
- COOLING & STRAINING TANK
- PUMP STATIONS
- PAINT SETTLING TANK
- TESTING SUMP
- SILT TRAP
- SILT PIT
- LIGHT & HEAVY DUTY GATIC ACCESS COVERS
- PHOTOGRAPHIC SINK
- SMALL & LARGE VALVE BOXES
- CUSTOM FABRICATION OF PVC, POLYPROPYLENE & PERSPEX

Pioneer Plastics
3/2137 Frankston-Flinders Rd,
Hastings 3915

p-(03) 9775 0203
sales@pioneerplastics.com.au

BELOW GROUND ACID NEUTRALIZING TANK

PP BG3

SECTION VIEW

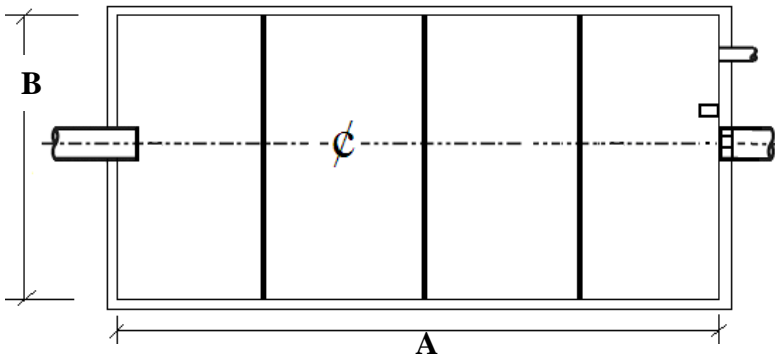
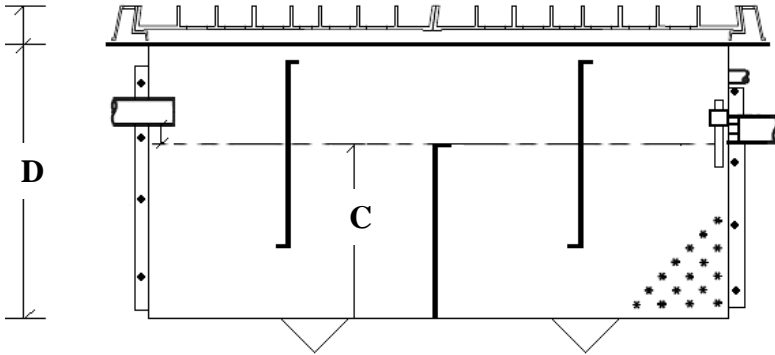

PLAN VIEW

CAPACITY LITRES	A (L)	B (W)	C (WL)	D (D)
250	900	600	470	770
300	900	600	560	860
400	900	600	750	1050
600	1500	600	670	970
800	1500	600	900	1200
1100	1500	600	1230	1530
1500	2000	750	1000	1300
2000	2500	750	1070	1370
2500	1900	1200	1100	1400
3000	2800	1200	900	1200
3500	2800	1200	1050	1350
4000	2800	1200	1200	1500
4500	2800	1200	1340	1640
5000	2800	1200	1490	1790

NOTE-DIMENSIONS IN MILLIMETERS

- ✓ Designed for below ground installations
- ✓ Manufactured from 6mm Polypropylene or PVC
- ✓ Factory fitted with 100mm inlet/outlet/vent connections standard
- ✓ Cement mortar test block to be supplied & fitted by Trade Waste Inspector
- ✓ Standard fittings supplied with tank-
- 3 equally spaced baffles
- bracket only for Test Block
- inlet/outlet/vent connections are 100mm
- ✓ **Marble chips available at additional cost.**
- ✓ Cast iron access covers capable of being removed by one person should be fitted (**available at additional cost**)
- ✓ Tanks must be surrounded with 100mm thick concrete walls & base
- ✓ When space limitations apply, equivalent capacity tanks can be manufactured to order. Inlet, outlet and vent positions can be altered to suit clients specific needs

OTHER PIONEER PRODUCTS INCLUDE-

- ABOVE & BELOW GROUND FOOD & OIL INTERCEPTOR/GREASE TRAP
- ABOVE GROUND MIXING TANKS
- ABOVE GROUND ACID NEUTRALIZING TANK
- SOLVENT & OIL INTERCEPTOR
- PETROL & OIL INTERCEPTOR
- SETTLING TANK/PLASTER TRAP
- COOLING & STRAINING TANK
- PUMP STATIONS
- PAINT SETTLING TANK
- TESTING SUMP
- SILT TRAP
- SILT PIT
- LIGHT & HEAVY DUTY GATIC ACCESS COVERS
- PHOTOGRAPHIC SINK
- SMALL & LARGE VALVE BOXES
- CUSTOM FABRICATION OF PVC, POLYPROPYLENE & PERSPEX

Pioneer Plastics
 3/2137 Frankston-Flinders Rd,
 Hastings 3915

p-(03) 9775 0203
 sales@pioneerplastics.com.au

ABOVE GROUND SOLVENT & OIL INTERCEPTOR

PP AG4

SECTION VIEW

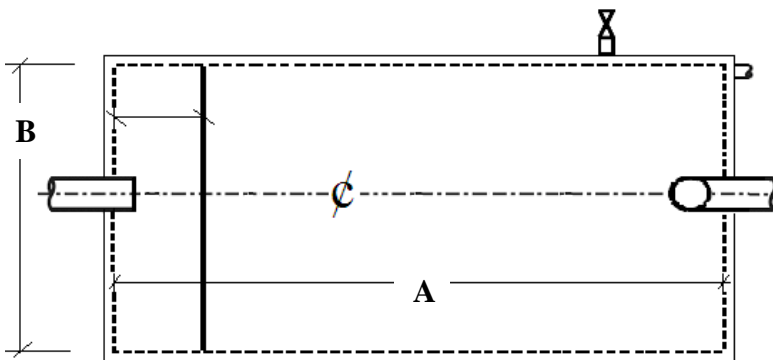
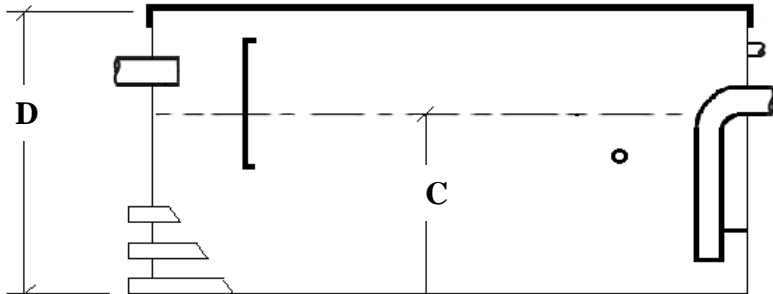

PLAN VIEW

CAPACITY LITRES	A (L)	B (W)	C (WL)	D (D)
100	700	400	360	560
150	700	400	540	740
200	700	400	720	920
250	1180	500	450	750
300	1180	600	450	750
400	1180	600	600	900
600	1460	830	510	810
800	1460	830	680	980
1000	1460	830	850	1150
1100	1460	830	930	1230
1500	1460	830	1270	1570
2000	2000	950	1060	1360
2500	2960	950	890	1190
3000	2960	950	1080	1380
3500	2960	1460	830	1130
4000	2960	1460	950	1250
4500	2960	1460	1070	1370
5000	2960	1460	1190	1490

NOTE-DIMENSIONS IN MILLIMETERS

- ✓ Designed for above ground installations
- ✓ Manufactured from 6mm Polypropylene or PVC
- ✓ Factory fitted with 100mm inlet/outlet/vent connections standard
- ✓ Standard fittings supplied with tank-
 - Sampling valve socket & drum tap
 - Drain valve socket & drum tap
 - Removable air tight covers supplied with all tanks
(Loose fitting lids not acceptable due to odors created by waste water)
- ✓ Tanks larger than 399 liters capacity have external bracing fitted for strength & support. Add an additional 100mm to the length and width dimensions for the approximate size when steel rails are fitted
- ✓ When space limitations apply, equivalent capacity tanks can be manufactured to order. Inlet, outlet and vent positions can be altered to suit clients specific needs

OTHER PIONEER PRODUCTS INCLUDE-

- ABOVE & BELOW GROUND FOOD & OIL INTERCEPTOR/GREASE TRAP
- ABOVE GROUND MIXING TANKS
- ABOVE GROUND ACID NEUTRALIZING TANK
- PETROL & OIL INTERCEPTOR
- SETTLING TANK/PLASTER TRAP
- COOLING & STRAINING TANK
- PUMP STATIONS
- PAINT SETTLING TANK
- TESTING SUMP
- SILT TRAP
- SILT PIT
- LIGHT & HEAVY DUTY GATIC ACCESS COVERS
- PHOTOGRAPHIC SINK
- SMALL & LARGE VALVE BOXES
- CUSTOM FABRICATION OF PVC, POLYPROPYLENE & PERSPEX

Pioneer Plastics
3/2137 Frankston-Flinders Rd,
Hastings 3915

p-(03) 9775 0203
sales@pioneerplastics.com.au

BELOW GROUND PETROL & OIL INTERCEPTOR

PP BG4

SECTION VIEW

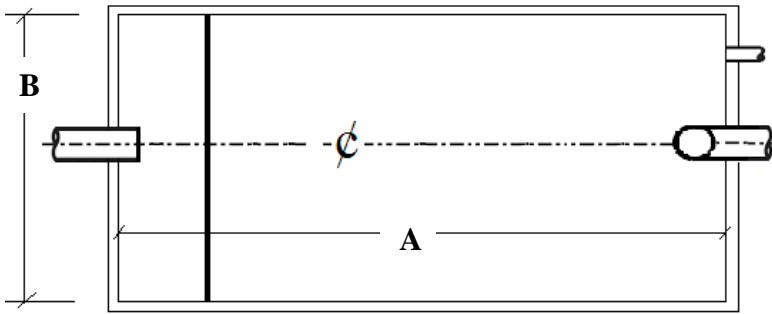
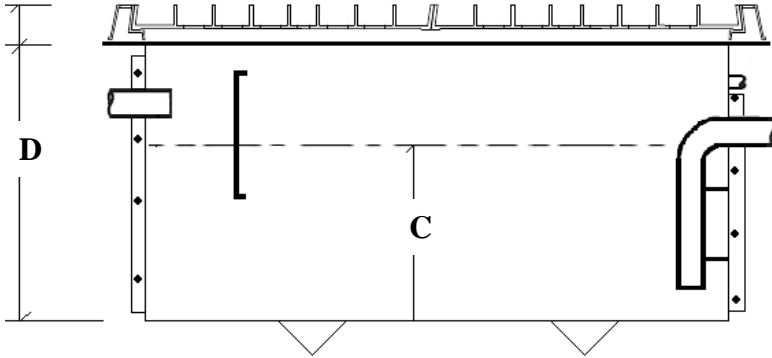

PLAN VIEW

CAPACITY LITRES	A (L)	B (W)	C (WL)	D (D)
1140	1890	600	1010	1410
1500	2385	750	950	1350
2000	2385	750	1120	1520
2500	2800	900	1000	1400
3000	2800	900	1200	1600
3500	2800	900	1390	1790
4000	2800	900	1590	1990
4500	3400	900	1480	1880
5000	3400	900	1640	2040

NOTE-DIMENSIONS IN MILLIMETERS

- ✓ Designed for below ground installations
- ✓ Manufactured from 6mm Polypropylene or PVC
- ✓ Standard fittings supplied with tank-
- Factory fitted with 100mm inlet/outlet/vent connections as standard
- Cast iron access covers capable of being removed by one person should be fitted (**available at additional cost**)
- ✓ Tanks must be surrounded with 100mm thick concrete walls & base
- ✓ When space limitations apply, equivalent capacity tanks can be manufactured to order. Inlet, outlet and vent positions can be altered to suit clients specific needs

OTHER PIONEER PRODUCTS INCLUDE-

- ABOVE & BELOW GROUND FOOD & OIL INTERCEPTOR/GREASE TRAP
- ABOVE GROUND MIXING TANKS
- ABOVE GROUND ACID NEUTRALIZING TANK
- SOLVENT & OIL INTERCEPTOR
- SETTLING TANK/PLASTER TRAP
- COOLING & STRAINING TANK
- PUMP STATIONS
- PAINT SETTLING TANK
- TESTING SUMP
- SILT TRAP
- SILT PIT
- LIGHT & HEAVY DUTY GATIC ACCESS COVERS
- PHOTOGRAPHIC SINK
- SMALL & LARGE VALVE BOXES
- CUSTOM FABRICATION OF PVC, POLYPROPYLENE & PERSPEX

Pioneer Plastics
3/2137 Frankston-Flinders Rd,
Hastings 3915

p-(03) 9775 0203
sales@pioneerplastics.com.au

ABOVE GROUND SETTLING TANK

PP AG5

SECTION VIEW

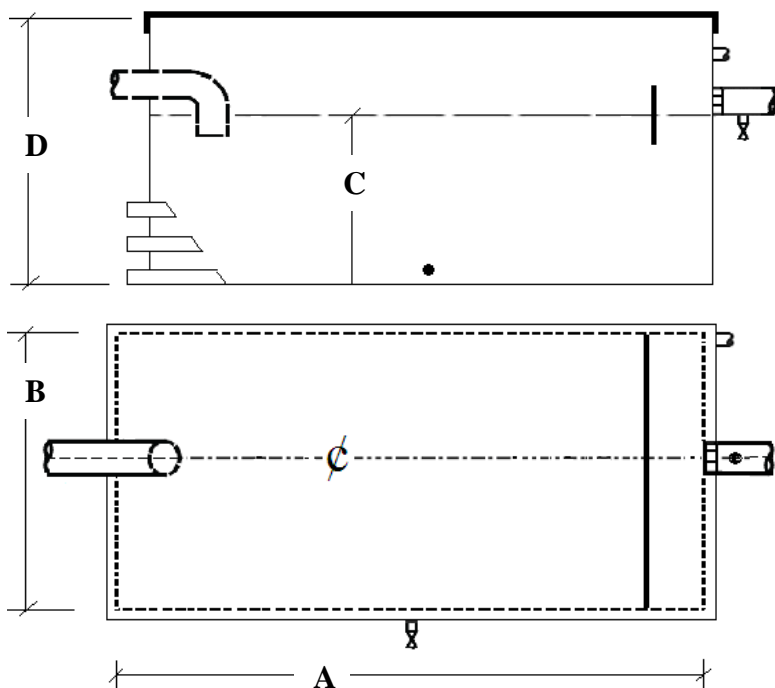

PLAN VIEW

CAPACITY LITRES	A (L)	B (W)	C (WL)	D (D)
100	610	410	400	550
150	750	450	450	600
200	750	450	600	750
250	1180	500	450	750
300	1180	600	450	750
400	1180	600	600	900
600	1460	830	510	810
800	1460	830	680	980
1000	1460	830	850	1150
1100	1460	830	930	1230
1500	1460	830	1270	1570
2000	2000	950	1060	1360
2500	2960	950	890	1190
3000	2960	950	1080	1380
3500	2960	1460	830	1130
4000	2960	1460	950	1250
4500	2960	1460	1070	1370
5000	2960	1460	1190	1490

NOTE-DIMENSIONS IN MILLIMETERS

- ✓ Designed for above ground installations, settling tanks are also known as plaster traps
- ✓ Manufactured from 6mm Polypropylene or PVC
- ✓ Factory fitted with inlet/outlet/vent connections standard
- ✓ Standard fittings supplied with tank-
 - Drain valve socket & drum tap
 - sampling valve socket & drum tap
- Removable air tight covers supplied with all tanks
(Loose fitting lids not acceptable due to odors created by waste water)
- ✓ Tanks larger than 399 liters capacity have external bracing fitted for strength & support. Add an additional 100mm to the length and width dimensions for the approximate size when steel rails are fitted
- ✓ When space limitations apply, equivalent capacity tanks can be manufactured to order. Inlet, outlet and vent positions can be altered to suit clients specific needs

OTHER PIONEER PRODUCTS INCLUDE-

- ABOVE & BELOW GROUND FOOD & OIL INTERCEPTOR/GREASE TRAP
- ABOVE GROUND MIXING TANKS
- ABOVE GROUND ACID NEUTRALIZING TANK
- SOLVENT & OIL INTERCEPTOR
- PETROL & OIL INTERCEPTOR
- SETTLING TANK/PLASTER TRAP
- COOLING & STRAINING TANK
- PUMP STATIONS
- PAINT SETTLING TANK
- TESTING SUMP
- SILT TRAP
- SILT PIT
- LIGHT & HEAVY DUTY GATIC ACCESS COVERS
- PHOTOGRAPHIC SINK
- SMALL & LARGE VALVE BOXES
- CUSTOM FABRICATION OF PVC, POLYPROPYLENE & PERSPEX

Pioneer Plastics
3/2137 Frankston-Flinders Rd,
Hastings 3915

p-(03) 9775 0203
sales@pioneerplastics.com.au

BELOW GROUND SETTLING TANK

PP BG5

SECTION VIEW

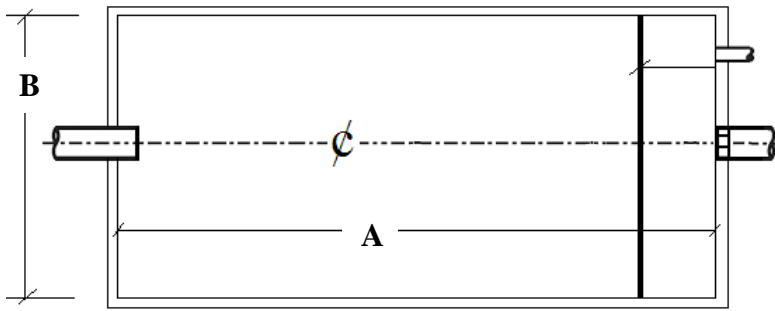
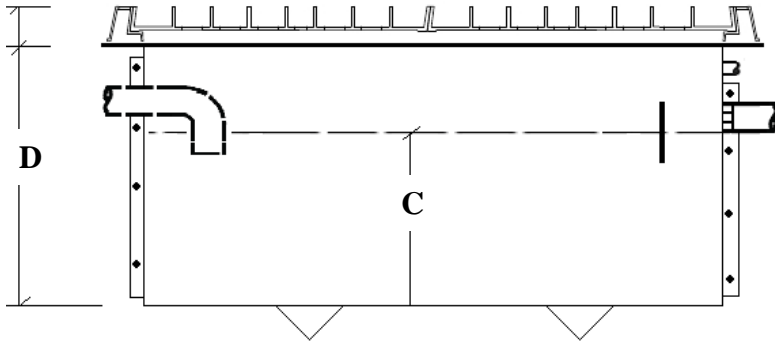

PLAN VIEW

CAPACITY LITRES	A (L)	B (W)	C (WL)	D (D)
250	900	600	470	770
300	900	600	560	860
400	900	600	750	1050
600	1500	600	670	970
800	1500	600	900	1200
1100	1500	600	1230	1530
1500	2000	750	1000	1300
2000	2500	750	1070	1370
2500	1900	1200	1100	1400
3000	2800	1200	900	1200
3500	2800	1200	1050	1350
4000	2800	1200	1200	1500
4500	2800	1200	1340	1640
5000	2800	1200	1490	1790

NOTE-DIMENSIONS IN MILLIMETERS

- ✓ Designed for below ground installations
- ✓ Manufactured from 6mm Polypropylene or PVC
- ✓ Standard fittings supplied with tank-
- ✓ Factory fitted with 100mm inlet/outlet/vent connections as standard
- ✓ Cast iron access covers capable of being removed by one person should be fitted (**available at additional cost**)
- ✓ Tanks must be surrounded with 100mm thick concrete walls & base
- ✓ When space limitations apply, equivalent capacity tanks can be manufactured to order. Inlet, outlet and vent positions can be altered to suit clients specific needs

OTHER PIONEER PRODUCTS INCLUDE-

- ABOVE & BELOW GROUND FOOD & OIL INTERCEPTOR/GREASE TRAP
- ABOVE GROUND MIXING TANKS
- ABOVE GROUND ACID NEUTRALIZING TANK
- SOLVENT & OIL INTERCEPTOR
- PETROL & OIL INTERCEPTOR
- SETTLING TANK/PLASTER TRAP
- COOLING & STRAINING TANK
- PUMP STATIONS
- PAINT SETTLING TANK
- TESTING SUMP
- SILT TRAP
- SILT PIT
- LIGHT & HEAVY DUTY GATIC ACCESS COVERS
- PHOTOGRAPHIC SINK
- SMALL & LARGE VALVE BOXES
- CUSTOM FABRICATION OF PVC, POLYPROPYLENE & PERSPEX

Pioneer Plastics
3/2137 Frankston-Flinders Rd,
Hastings 3915

p-(03) 9775 0203
sales@pioneerplastics.com.au

ABOVE GROUND COOLING & STRAINING TANK

PP AG6

SECTION VIEW

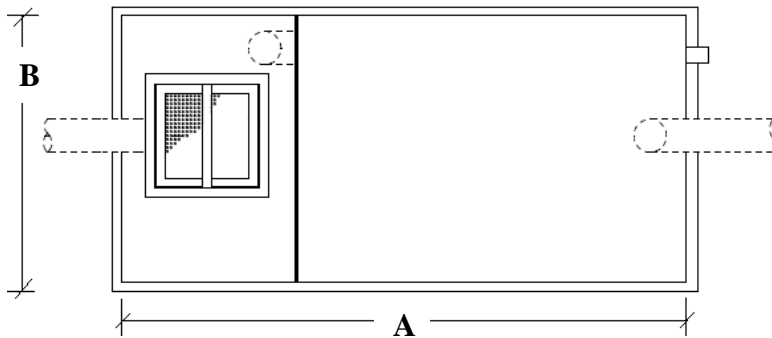
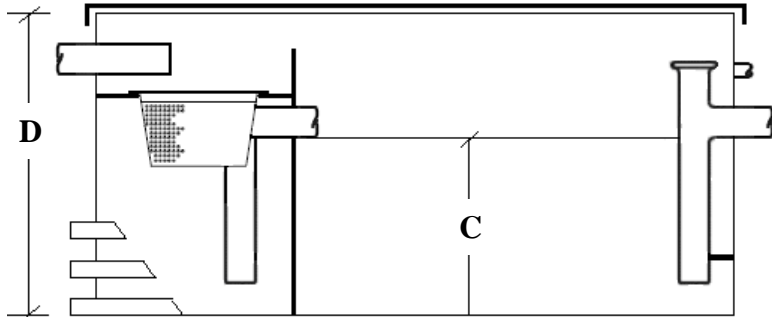

PLAN VIEW

CAPACITY LITRES	A (L)	B (W)	C (WL)	D (D)
100	675	450	400	750
150	750	450	450	800
200	750	450	600	950
250	1180	500	450	800
300	1180	600	450	800
400	1180	600	600	950
600	1460	830	510	860
800	1460	830	680	1030
1000	1460	830	850	1200
1100	1460	830	930	1280
1500	1460	830	1270	1620
2000	2000	950	1060	1360
2500	2960	950	890	1240
3000	2960	950	1080	1430
3500	2960	1460	830	1180
4000	2960	1460	950	1300
4500	2960	1460	1070	1420
5000	2960	1460	1190	1540

NOTE-DIMENSIONS IN MILLIMETERS

- ✓ Designed for above ground installations
- ✓ Manufactured from 6mm Polypropylene or PVC
- ✓ Factory fitted with inlet/outlet/vent connections standard
- ✓ Standard fittings supplied with tank-
- Removable straining basket
- Removable air tight covers supplied with all tanks
(Loose fitting lids not acceptable due to odors created by waste water)
- ✓ All capacity tanks have external bracing fitted for strength & support. Add an additional 100mm to the length and width dimensions for the approximate size when steel rails are fitted
- ✓ When space limitations apply, equivalent capacity tanks can be manufactured to order. Inlet, outlet and vent positions can be altered to suit clients specific needs

OTHER PIONEER PRODUCTS INCLUDE-

- ABOVE & BELOW GROUND FOOD & OIL INTERCEPTOR/GREASE TRAP
- ABOVE GROUND MIXING TANKS
- ABOVE GROUND ACID NEUTRALIZING TANK
- SOLVENT & OIL INTERCEPTOR
- PETROL & OIL INTERCEPTOR
- SETTLING TANK/PLASTER TRAP
- COOLING & STRAINING TANK
- PUMP STATIONS
- PAINT SETTLING TANK
- TESTING SUMP
- SILT TRAP
- SILT PIT
- LIGHT & HEAVY DUTY GATIC ACCESS COVERS
- PHOTOGRAPHIC SINK
- SMALL & LARGE VALVE BOXES
- CUSTOM FABRICATION OF PVC, POLYPROPYLENE & PERSPEX

Pioneer Plastics
3/2137 Frankston-Flinders Rd,
Hastings 3915

p-(03) 9775 0203
sales@pioneerplastics.com.au

BELOW GROUND COOLING & STRAINING TANK

PP BG6

SECTION VIEW

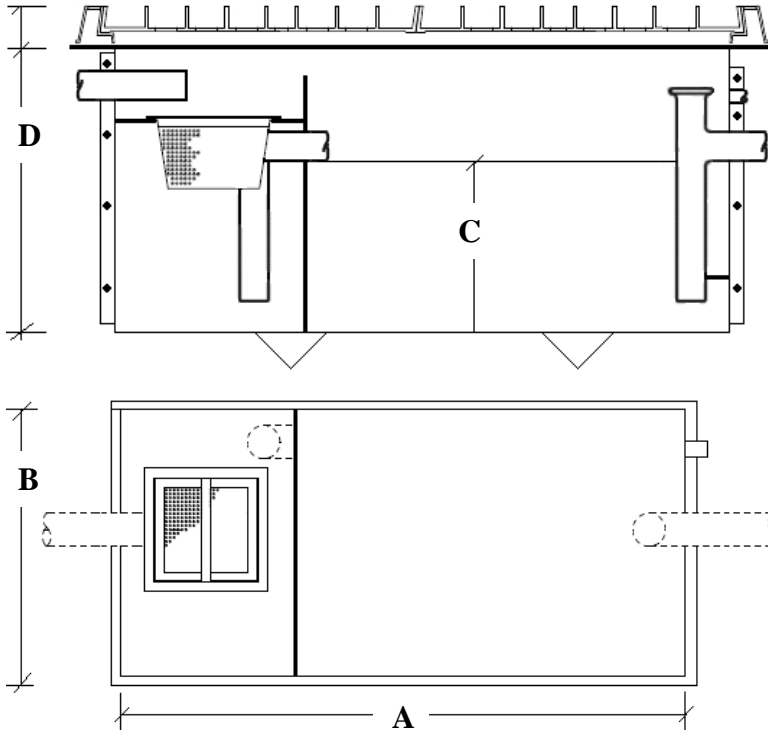

PLAN VIEW

CAPACITY LITRES	A (L)	B (W)	C (WL)	D (D)
250	900	600	470	820
300	900	600	560	910
400	900	600	750	1100
600	1500	600	670	1095
800	1500	600	900	1325
1100	1500	600	1230	1655
1500	2000	750	1000	1425
2000	2500	750	1070	1495
2500	1900	1200	1100	1450
3000	2800	1200	900	1250
3500	2800	1200	1050	1400
4000	2800	1200	1200	1550
4500	2800	1200	1340	1690
5000	2800	1200	1490	1840

NOTE-DIMENSIONS IN MILLIMETERS

- ✓ Designed for below ground installations
- ✓ Manufactured from 6mm Polypropylene or PVC
- ✓ Factory fitted with 100mm inlet/outlet/vent connections standard
- ✓ Standard fittings supplied with tank-
- Removable straining basket
- ✓ Cast iron access covers capable of being removed by one person should be fitted (**available at additional cost**)
- ✓ Tanks must be surrounded with 100mm thick concrete walls & base
- ✓ When space limitations apply, equivalent capacity tanks can be manufactured to order. Inlet, outlet and vent positions can be altered to suit clients specific needs

OTHER PIONEER PRODUCTS INCLUDE-

- ABOVE & BELOW GROUND FOOD & OIL INTERCEPTOR/GREASE TRAP
- ABOVE GROUND MIXING TANKS
- ABOVE GROUND ACID NEUTRALIZING TANK
- SOLVENT & OIL INTERCEPTOR
- PETROL & OIL INTERCEPTOR
- SETTLING TANK/PLASTER TRAP
- COOLING & STRAINING TANK
- PUMP STATIONS
- PAINT SETTLING TANK
- TESTING SUMP
- SILT TRAP
- SILT PIT
- LIGHT & HEAVY DUTY GATIC ACCESS COVERS
- PHOTOGRAPHIC SINK
- SMALL & LARGE VALVE BOXES
- CUSTOM FABRICATION OF PVC, POLYPROPYLENE & PERSPEX

Pioneer Plastics
 3/2137 Frankston-Flinders Rd,
 Hastings 3915

p-(03) 9775 0203
 sales@pioneerplastics.com.au

ABOVE GROUND PUMP STATION

PP AG7

MODEL	PUMP CONFIGURATION	PUMP CONTROL SYSTEM	CAPACITY LTRS	A (DIA)	B (D)
PIP AG7	NO PUMP	NOT FITTED	64	450	400
PIP AG7 SC	SINGLE VORTEX	YES	64	450	400
PIP AG7 TC	TWIN VORTEX	YES	64	450	400
CUSTOM	SIZE AND FIT OUT AS REQUESTED				

NOTE-DIMENSIONS IN MILLIMETERS

SECTION VIEW

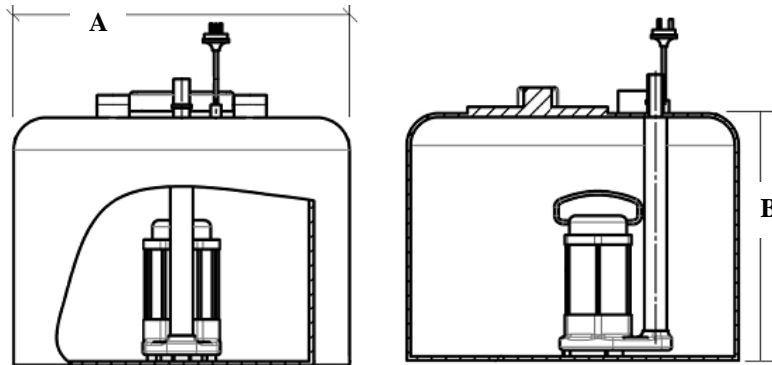

- ✓ Designed for above ground installations
- ✓ Manufactured from Polyethylene
- ✓ Standard fittings supplied with tank-
- 50mm inlet & vent
- 25mm pump outlet (**when pump is factory fitted**)
- Poly screw cap lid
- Submersible pump (**check model description**)
- ✓ Pump station must be installed to relevant plumbing and local authority regulations
- ✓ Larger capacity tanks can be manufactured to order
- ✓ Inlet, outlet and vent positions can be altered to suit clients specific needs
- ✓ Various pumps including High flow & grinder available on request

OTHER PIONEER PRODUCTS INCLUDE-

- ABOVE & BELOW GROUND FOOD & OIL INTERCEPTOR/GREASE TRAP
- ABOVE GROUND MIXING TANKS
- ABOVE GROUND ACID NEUTRALIZING TANK
- SOLVENT & OIL INTERCEPTOR
- PETROL & OIL INTERCEPTOR
- SETTLING TANK/PLASTER TRAP
- COOLING & STRAINING TANK
- PUMP STATIONS
- PAINT SETTLING TANK
- TESTING SUMP
- SILT TRAP
- SILT PIT
- LIGHT & HEAVY DUTY GATIC ACCESS COVERS
- PHOTOGRAPHIC SINK
- SMALL & LARGE VALVE BOXES
- CUSTOM FABRICATION OF PVC, POLYPROPYLENE & PERSPEX

Pioneer Plastics
 3/2137 Frankston-Flinders Rd,
 Hastings 3915

p-(03) 9775 0203
 sales@pioneerplastics.com.au

BELOW GROUND PUMP STATION

PP BG7

MODEL	PUMP CONFIGURATION	PUMP CONTROL SYSTEM	CAPACITY LTRS	A (DIA)	B (D)
PIP BG7	NO PUMP	NOT FITTED	66-532	460-950	400-750
PIP BG7 SC	SINGLE VORTEX	YES	66-532	460-950	400-750
PIP BG7 TC	TWIN VORTEX	YES	66-532	460-950	400-750
CUSTOM	SIZE AND FIT OUT AS REQUESTED				

SECTION VIEW

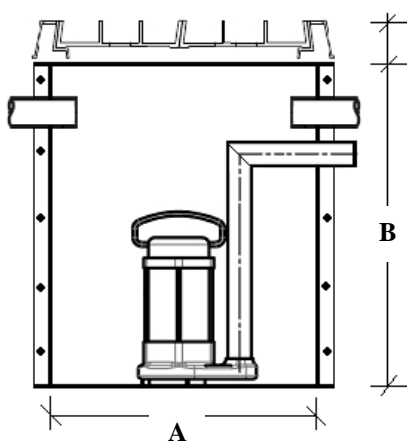

NOTE-DIMENSIONS IN MILLIMETERS

PLAN VIEW

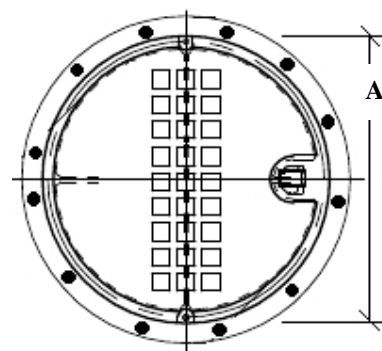

- ✓ Designed for below ground installations
- ✓ Manufactured from 6mm Polypropylene or PVC
- ✓ Standard fittings supplied with tank-
- 100mm inlet & vent
- 25mm pump outlet (**when pump is factory fitted**)
- Submersible pump (**check model description**)
- ✓ Cast iron access covers capable of being removed by one person should be fitted (**available at additional cost**)
- ✓ Tanks should be surrounded with 100mm thick concrete walls & base
- ✓ Pump station must be installed to relevant plumbing and local authority regulations
- ✓ Larger capacity tanks can be manufactured to order
- ✓ Inlet, outlet and vent positions can be altered to suit clients specific needs
- ✓ Various pumps including High flow & grinder available on request

OTHER PIONEER PRODUCTS INCLUDE-

- ABOVE & BELOW GROUND FOOD & OIL INTERCEPTOR/GREASE TRAP
- ABOVE GROUND MIXING TANKS
- ABOVE GROUND ACID NEUTRALIZING TANK
- SOLVENT & OIL INTERCEPTOR
- PETROL & OIL INTERCEPTOR
- SETTLING TANK/PLASTER TRAP
- COOLING & STRAINING TANK
- PUMP STATIONS
- PAINT SETTLING TANK
- TESTING SUMP
- SILT TRAP
- SILT PIT
- LIGHT & HEAVY DUTY GATIC ACCESS COVERS
- PHOTOGRAPHIC SINK
- SMALL & LARGE VALVE BOXES
- CUSTOM FABRICATION OF PVC, POLYPROPYLENE & PERSPEX

Pioneer Plastics
 3/2137 Frankston-Flinders Rd,
 Hastings 3915

p-(03) 9775 0203
 sales@pioneerplastics.com.au

ABOVE GROUND PAINT SETTLING TANK

PP AG8

SECTION VIEW

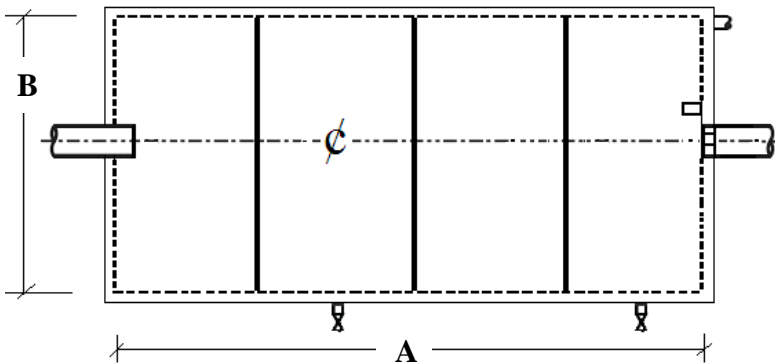
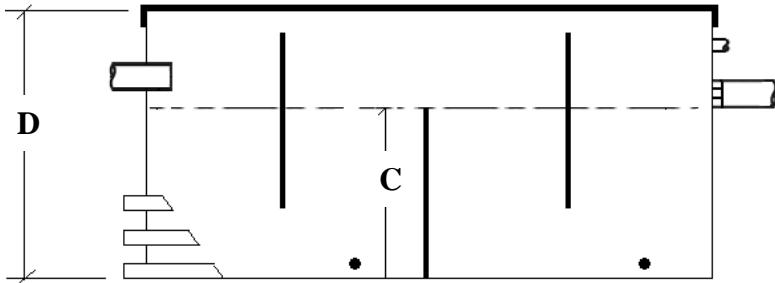

PLAN VIEW

CAPACITY LITRES	A (L)	B (W)	C (WL)	D (D)
100	610	410	400	550
150	750	450	450	600
200	750	450	600	750
250	1180	500	450	750
300	1180	600	450	750
400	1180	600	600	900
600	1460	830	510	810
800	1460	830	680	980
1000	1460	830	850	1150
1100	1460	830	930	1230
1500	1460	830	1270	1570
2000	2000	950	1060	1360
2500	2960	950	890	1190
3000	2960	950	1080	1380
3500	2960	1460	830	1130
4000	2960	1460	950	1250
4500	2960	1460	1070	1370
5000	2960	1460	1190	1490

NOTE-DIMENSIONS IN MILLIMETERS

- ✓ Designed for above ground installations
- ✓ Manufactured from 6mm Polypropylene or PVC
- ✓ Factory fitted with inlet/outlet/vent connections standard
- ✓ Standard fittings supplied with tank-
- 3 equally spaced baffles
- Twin sump drain points
- Removable air tight covers supplied with all tanks
(Loose fitting lids not acceptable due to odors created by waste water)
- ✓ Tanks larger than 399 liters capacity have external bracing fitted for strength & support. Add an additional 100mm to the length and width dimensions for the approximate size when steel rails are fitted
- ✓ When space limitations apply, equivalent capacity tanks can be manufactured to order. Inlet, outlet and vent positions can be altered to suit clients specific needs

OTHER PIONEER PRODUCTS INCLUDE-

- ABOVE & BELOW GROUND FOOD & OIL INTERCEPTOR/GREASE TRAP
- BELOW GROUND MIXING TANKS
- ACID NEUTRALIZING TANK
- SOLVENT & OIL INTERCEPTOR
- PETROL & OIL INTERCEPTOR
- SETTLING TANK/PLASTER TRAP
- COOLING & STRAINING TANK
- PUMP STATIONS
- PAINT SETTLING TANK
- TESTING SUMP
- SILT TRAP
- SILT PIT
- LIGHT & HEAVY DUTY GATIC ACCESS COVERS
- PHOTOGRAPHIC SINK
- SMALL & LARGE VALVE BOXES
- CUSTOM FABRICATION OF PVC, POLYPROPYLENE & PERSPEX

Pioneer Plastics
 3/2137 Frankston-Flinders Rd,
 Hastings 3915

p-(03) 9775 0203
 sales@pioneerplastics.com.au

BELOW GROUND PAINT SETTLING TANK

PP BG8

SECTION VIEW

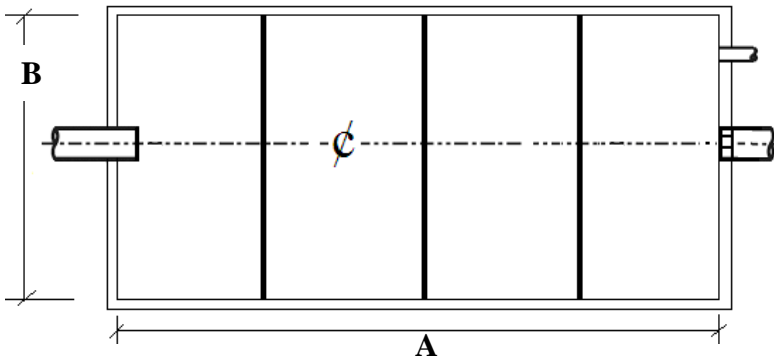
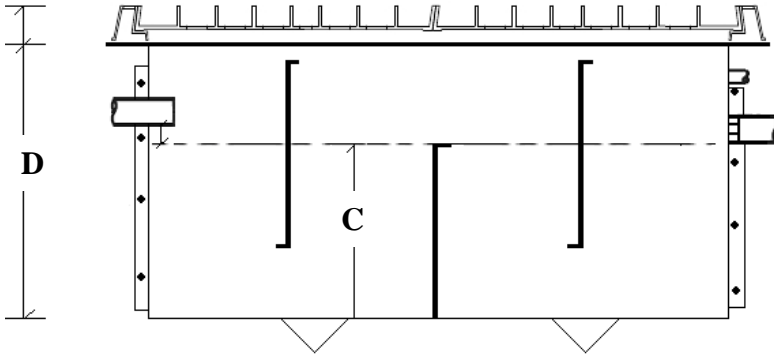

PLAN VIEW

CAPACITY LITRES	A (L)	B (W)	C (WL)	D (D)
250	900	600	470	770
300	900	600	560	860
400	900	600	750	1050
600	1500	600	670	970
800	1500	600	900	1200
1100	1500	600	1230	1530
1500	2000	750	1000	1300
2000	2500	750	1070	1370
2500	1900	1200	1100	1400
3000	2800	1200	900	1200
3500	2800	1200	1050	1350
4000	2800	1200	1200	1500
4500	2800	1200	1340	1640
5000	2800	1200	1490	1790

NOTE-DIMENSIONS IN MILLIMETERS

- ✓ Designed for below ground installations
- ✓ Manufactured from 6mm Polypropylene or PVC
- ✓ Factory fitted with 100mm inlet/outlet/vent connections standard
- ✓ Standard fittings supplied with tank-
- 3 equally spaced baffles
- ✓ Cast iron access covers capable of being removed by one person should be fitted (**available at additional cost**)
- ✓ Tanks must be surrounded with 100mm thick concrete walls & base
- ✓ When space limitations apply, equivalent capacity tanks can be manufactured to order. Inlet, outlet and vent positions can be altered to suit clients specific needs

OTHER PIONEER PRODUCTS INCLUDE-

- ABOVE & BELOW GROUND FOOD & OIL INTERCEPTOR/GREASE TRAP
- ABOVE GROUND MIXING TANKS
- ACID NEUTRALIZING TANK
- SOLVENT & OIL INTERCEPTOR
- PETROL & OIL INTERCEPTOR
- SETTLING TANK/PLASTER TRAP
- COOLING & STRAINING TANK
- PUMP STATIONS
- PAINT SETTLING TANK
- TESTING SUMP
- SILT TRAP
- SILT PIT
- LIGHT & HEAVY DUTY GATIC ACCESS COVERS
- PHOTOGRAPHIC SINK
- SMALL & LARGE VALVE BOXES
- CUSTOM FABRICATION OF PVC, POLYPROPYLENE & PERSPEX

Pioneer Plastics
 3/2137 Frankston-Flinders Rd,
 Hastings 3915

p-(03) 9775 0203
 sales@pioneerplastics.com.au

ABOVE (AG9) & BELOW (BG9) GROUND TESTING SUMP

PP AG9

PP BG9

TYPE	A (L)	B (W)	C (D)
TESTING SUMP	300	300	400

TYPE	A (L)	B (W)	C (D)
TESTING SUMP	300	300	400

NOTE-DIMENSIONS IN MILLIMETERS

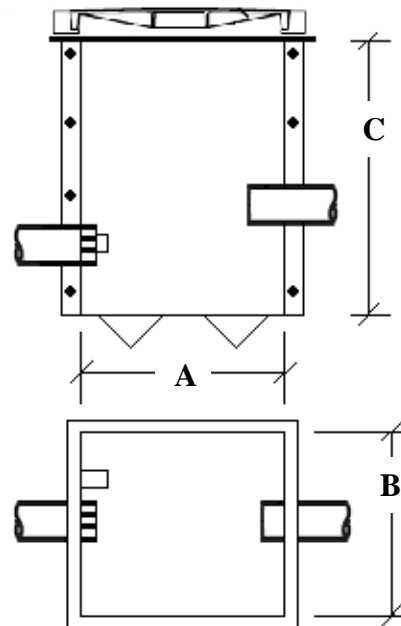
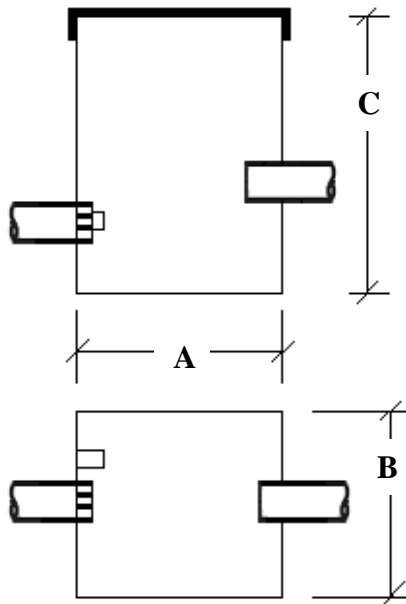

- ✓ Designed for above & below ground installations
- ✓ Manufactured from 6mm Polypropylene or PVC
- ✓ Factory fitted with 100mm inlet/outlet connections standard
- fixed grate built into tank
- bracket for cement mortar test block (**block not supplied**)
- Removable loose fitting lid supplied with above ground model
- Below ground model requires cast iron access cover capable of being removed by one person (**available at additional cost**)
- ✓ Below ground model must be surrounded with 100mm thick concrete walls & base
- ✓ Can be manufactured to various dimensions on request
- ✓ Inlet, Outlet positions can be altered to suit client's specific needs

OTHER PIONEER PRODUCTS INCLUDE-

- ABOVE & BELOW GROUND FOOD & OIL INTERCEPTOR/GREASE TRAP
- ABOVE GROUND MIXING TANKS
- ACID NEUTRALIZING TANK
- SOLVENT & OIL INTERCEPTOR
- PETROL & OIL INTERCEPTOR
- SETTLING TANK/PLASTER TRAP
- COOLING & STRAINING TANK
- PUMP STATIONS
- PAINT SETTLING TANK
- TESTING SUMP
- SILT TRAP
- SILT PIT
- LIGHT & HEAVY DUTY GATIC ACCESS COVERS
- PHOTOGRAPHIC SINK
- SMALL & LARGE VALVE BOXES
- CUSTOM FABRICATION OF PVC, POLYPROPYLENE & PERSPEX

Pioneer Plastics
3/2137 Frankston-Flinders Rd,
Hastings 3915

p-(03) 9775 0203
sales@pioneerplastics.com.au

SILT TRAP

PP ST

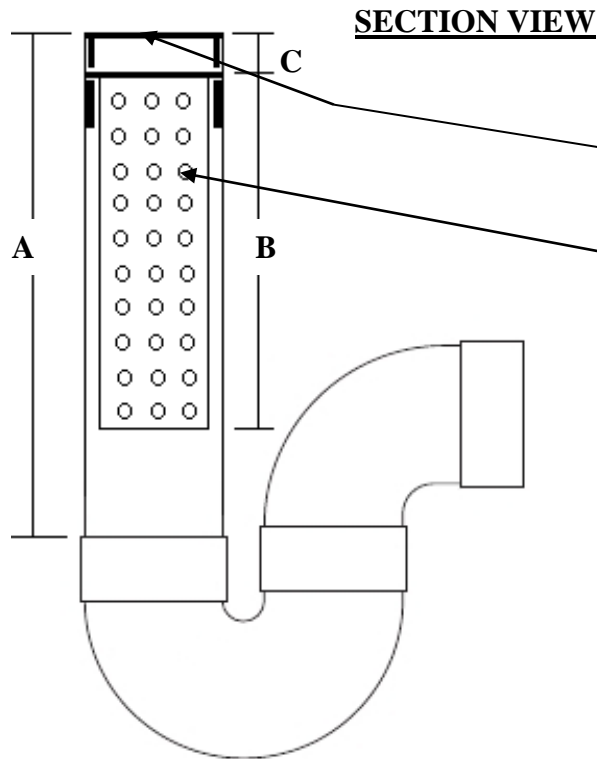

TYPE	A	B	C
SILT TRAP	240	210	25

NOTE-DIMENSIONS IN MILLIMETERS

REMOVABLE CHROME PLATED FLOOR GRATE

REMOVABLE STRAINING BASKET PERFORATED WITH M10 HOLES

- ✓ Designed for installation below ground in wash down areas for the collection of silt and small solids
- ✓ Manufactured entirely from 100mm PVC
- ✓ Standard fittings supplied with trap-
- Chrome plated floor grate
- M10 perforated removable straining basket

OTHER PIONEER PRODUCTS INCLUDE-

- ABOVE & BELOW GROUND FOOD & OIL INTERCEPTOR/GREASE TRAP
- ABOVE GROUND MIXING TANKS
- ABOVE GROUND ACID NEUTRALIZING TANK
- SOLVENT & OIL INTERCEPTOR
- PETROL & OIL INTERCEPTOR
- SETTLING TANK/PLASTER TRAP
- COOLING & STRAINING TANK
- PUMP STATIONS
- PAINT SETTLING TANK
- TESTING SUMP
- SILT TRAP
- SILT PIT
- LIGHT & HEAVY DUTY GATIC ACCESS COVERS
- PHOTOGRAPHIC SINK
- SMALL & LARGE VALVE BOXES
- CUSTOM FABRICATION OF PVC, POLYPROPYLENE & PERSPEX

Pioneer Plastics
3/2137 Frankston-Flinders Rd,
Hastings 3915

p-(03) 9775 0203
sales@pioneerplastics.com.au

SILT PIT

PP SP

TYPE	A	B	C	D	E	F	G
SILT TRAP	305	170	400	120	90	215	90

NOTE-DIMENSIONS IN MILLIMETERS

SECTION VIEW

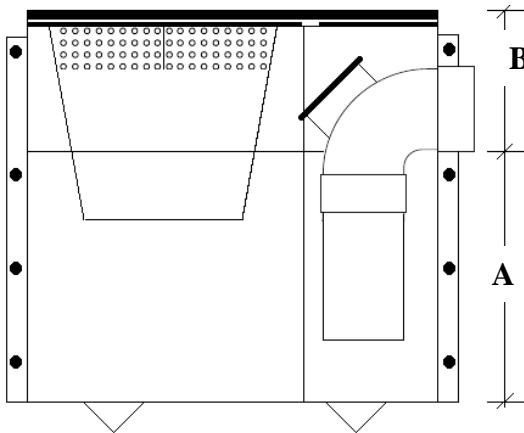

GRATE DETAIL

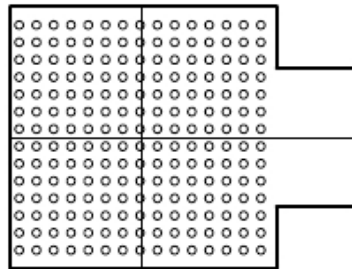

PLAN VIEW

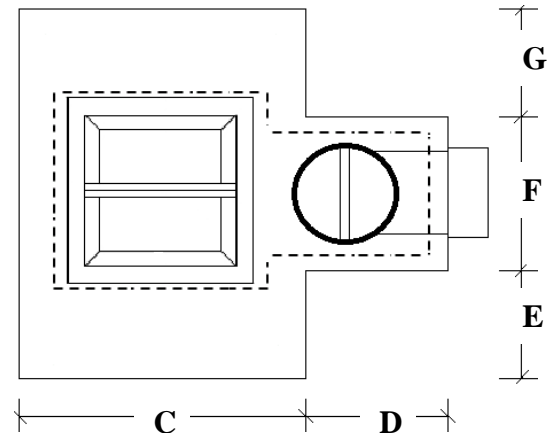

- ✓ Designed for installation below ground in wash down areas for the collection of silt and general solids
- ✓ Manufactured from 6mm Polypropylene or PVC
- ✓ Standard fittings supplied with trap-
- M10 perforated removable galvanized steel straining basket
- M10 perforated removable galvanized steel grate
- 100mm I.O outlet
- ✓ Tank must be surrounded with 100mm thick concrete walls & base

OTHER PIONEER PRODUCTS INCLUDE-

- ABOVE & BELOW GROUND FOOD & OIL INTERCEPTOR/GREASE TRAP
- ABOVE GROUND MIXING TANKS
- ABOVE GROUND ACID NEUTRALIZING TANK
- SOLVENT & OIL INTERCEPTOR
- PETROL & OIL INTERCEPTOR
- SETTLING TANK/PLASTER TRAP
- COOLING & STRAINING TANK
- PUMP STATIONS
- PAINT SETTLING TANK
- TESTING SUMP
- SILT TRAP
- SILT PIT
- LIGHT & HEAVY DUTY GATIC ACCESS COVERS
- PHOTOGRAPHIC SINK
- SMALL & LARGE VALVE BOXES
- CUSTOM FABRICATION OF PVC, POLYPROPYLENE & PERSPEX

Pioneer Plastics
3/2137 Frankston-Flinders Rd,
Hastings 3915

p-(03) 9775 0203
sales@pioneerplastics.com.au

PHOTOGRAPHIC SINK

PP PS

TYPE	A	B	C
SMALL SINK	600	300	250
MEDIUM SINK	1200	450	250
LARGE SINK	1800	600	250

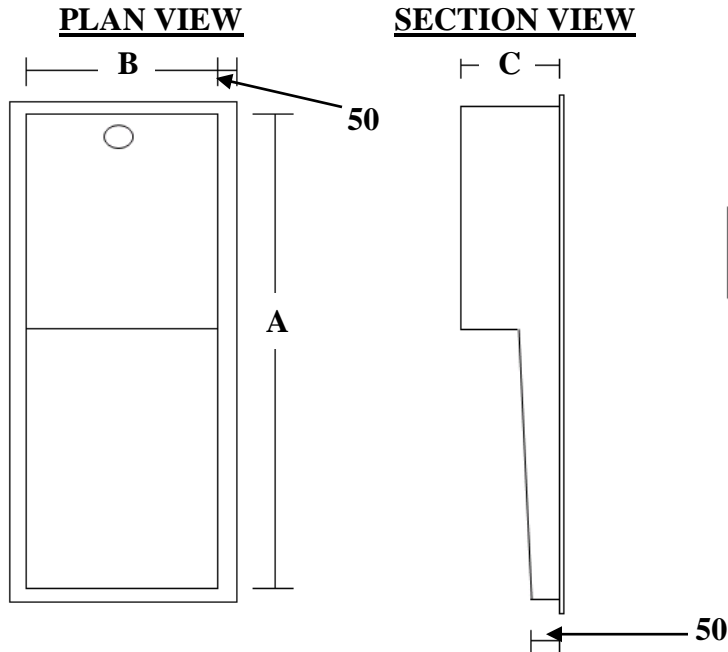

NOTE-DIMENSIONS IN MILLIMETERS

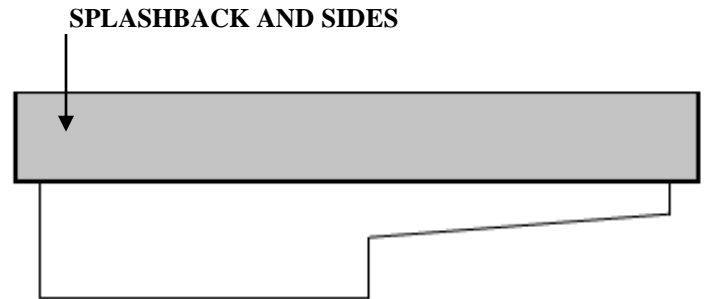

- ✓ Manufactured from White or Grey PVC
- ✓ Sink supplied with 50mm Poly Plug & Washer
- ✓ Custom splash back & sides available as an **optional extra**
- ✓ Custom size fabrication available including other materials such as polypropylene and polyethylene

OTHER PIONEER PRODUCTS INCLUDE-

- ABOVE & BELOW GROUND FOOD & OIL INTERCEPTOR/GREASE TRAP
- ABOVE GROUND MIXING TANKS
- ABOVE GROUND ACID NEUTRALIZING TANK
- SOLVENT & OIL INTERCEPTOR
- PETROL & OIL INTERCEPTOR
- SETTLING TANK/PLASTER TRAP
- COOLING & STRAINING TANK
- PUMP STATIONS
- PAINT SETTLING TANK
- TESTING SUMP
- SILT TRAP
- SILT PIT
- LIGHT & HEAVY DUTY GATIC ACCESS COVERS
- PHOTOGRAPHIC SINK
- SMALL & LARGE VALVE BOXES
- CUSTOM FABRICATION OF PVC, POLYPROPYLENE & PERSPEX

Pioneer Plastics
3/2137 Frankston-Flinders Rd,
Hastings 3915

p-(03) 9775 0203
sales@pioneerplastics.com.au